

EchoLink

Linking Example

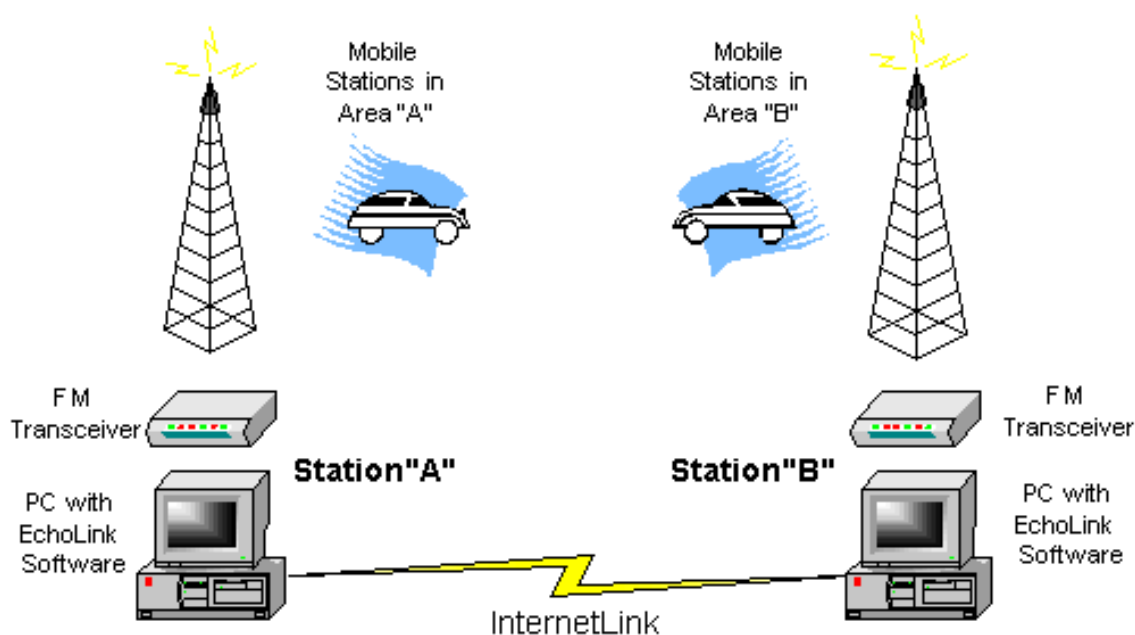

EchoLink[®] software allows licensed Amateur Radio stations to communicate with one another over the Internet, using voice-over-IP (VoIP) technology. The program allows worldwide connections to be made between stations, or from computer to station, greatly enhancing Amateur Radio's communications capabilities. There are more than 200,000 validated users worldwide — in 162 of the world's 193 nations — with about 4,000 online at any given time

www.echolink.org

North Ireland EchoLink Gateways

North Donegal Internet Repeaters



EI2IPG

Sysop Peter EI4JR



EI0IPG

Sysop Steve EI2IPG

Internet Repeater 145.7125 / 145.1125 MHz - 29.680 / 29.580MHz. Access 67Hz
Located in Inishowen Peninsula Carndonagh Co. Donegal IO65JG
24 Hour Internet Operation

Londonderry Internet Gateway



MB7ILD

Sysop Johnny GI4YWT

145.2875 MHz. *Came to life 11th September 2008.* Node No. 389438. Locator IO64IX
Access 110.9Hz
24 Hour Internet Operation

Ireland Conference Server - Node No. 2605

www.echoireland.com

EchoLink Internet Links in Ireland

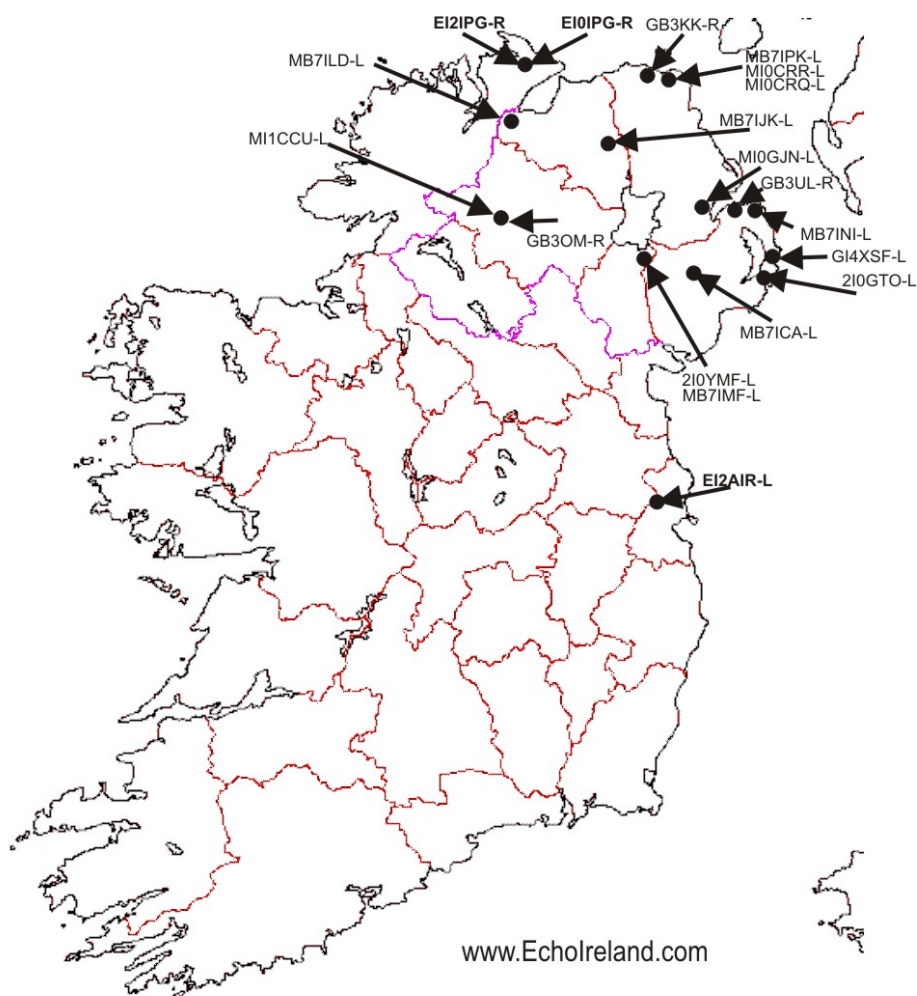

Call	Node	Frequency	Access Tone	Location	Sysop
E10IPG	29007	29.680 / 29.580 MHz	67 Hz CTCSS	Carndonagh, Inishowen County Donegal	EI2GYB
E12IPG	7125	145.7125 / 145.1125 MHz	67 Hz CTCSS or T/Burst	Carndonagh, Inishowen County Donegal	EI4JR
E12AIR	5747	145.2875 MHz	Carrier	Dunshaughlin	EI5HW
MB7ICA	322087	144.8250 MHz	77Hz CTCSS Tone	Dromara, Northern Ireland.	MI0PTK
MB7ICA	322087	50.5200 MHz	77Hz CTCSS Tone	Dromara, Northern Ireland.	MI0PTK
MB7INI	1717	145.3375 MHz	77Hz CTCSS Tone	Bangor, Northern Ireland.	GI7FOD
MB7IJK	268763	145.2125 MHz	110.9Hz CTCSS Tone	Kilrea, Northern Ireland	MI0AAZ
MB7ILD	389438	145.2875 MHz	110.9Hz CTCSS Tone	Londonderry, Northern Ireland	GI4YWT
MB7IMF	384564	145.2375 MHz	110.9Hz CTCSS Tone	Craigavon Armagh, Northern Ireland	2I0YMF
MB7IPK	409320	144.8375 MHz	77 Hz CTCSS	Ballycastle, Northern Ireland	MI0CRR
MI1CCU		145.3375 MHz	110.9Hz CTCSS Tone	Omagh, Northern Ireland	MI1CCU
MI0CRQ		29.5300 MHz	Carrier	Ballycastle, Northern Ireland	MI0CRQ
MI0CRQ		51.9300 MHz	Carrier	Ballycastle, Northern Ireland	MI0CRQ
MI0CRR		70.3625 MHz	Carrier	Ballycastle, Northern Ireland	MI0CRR
MI0GJN	392919	430.0750 MHz	67 Hz CTCSS	Newtownabbey, Northern Ireland	MI0GJN
GB3KK	388080	430.975 MHz	110.9Hz CTCSS Tone	Ballycastle, Northern Ireland	MI0MRV
GB3UL	404743	433.050 MHz	110.9Hz CTCSS Tone	Belfast, Northern Ireland	GI3USS
GB3OM	404743	433.3750 MHz	110.9Hz CTCSS Tone	Omagh, Northern Ireland	GI4XSV
GI4XSF	343109	144.8375 MHz	110.9Hz CTCSS Tone	Cloughey, County Down, Northern Ireland	GI4XSF
2I0GTO	19441	145.2875 MHz	110.9Hz CTCSS Tone	Portaferry, Northern Ireland	2I0GTO
2I0YMF	339735	430.0250 MHz	Carrier	Craigavon Armagh, Northern Ireland	2I0YMF

Internet Linking

In Southern Ireland there are only a few RF Internet Link's licensed. Only Clubs at the moment may apply for a gateway. If you need help setting up or want more information on setting up a link please email me and I will be very happy to help.

Applying for a gateway in Southern Ireland

The Internet Linking Operation application form is available from ComReg <http://www.comreg.ie>
At this time ComReg is only giving permission to clubs to run a gateway. I hope that your club will show some interest.

ComReg Internet Linking form

http://www.comreg.ie/publications/radio_experimenter_licence__automatic_station_operation.531.103198.p.html

Applying for a gateway in Northern Ireland

An NOV (Notice of variation) is required in Northern Ireland and applications are done on line. Only Full and Intermediate license holders can run a gateway. For full information and application visit the DCC (RSGB) <http://www.dcc.rsgb.org>.

If you do have permission to set up an RF internet link and need help with setting it up drop me an email peter@ei4jr.com. I have designed a number of simple interfaces that can be used for more info check out www.echoireland.com.

Internet linking is one of the fastest growing areas of our hobby, with hundreds of linked systems and tens of thousands of hams using Internet links around the world. Internet linking has come a long way from the early experiments of the 1990's, which involved a lot of manual intervention, to today's range of reliable, easy to use secure systems.

Growing numbers of hams are using VoIP, or Voice Over Internet Protocol, Using their PC only or in a combination with their radios for long-distance communication spanning hundreds or thousands of miles. They're using the Internet as the relay between their base stations, handhelds and mobile transceivers. For some radio amateurs the Internet is an anathema, for others it has changed their hobby and added new dimensions to their radio interests. One such development is the 'Internet Linking' of licensed radio amateurs using VoIP technology (Voice over Internet Protocol). VoIP is not new and has been experimented with commercially for some years. The success of commercial systems was limited by the available bandwidth and modem speeds, but with the increase in broadband technology commercial systems have become much more viable.

Radio amateurs have become increasingly interested in the technology as a way of bridging long-distance communication using a combination of the Internet and VHF or UHF transceivers. Just for clarification - Internet Linking does not allow radio amateurs to access web pages via radio, rather, it acts as a conduit for voice communication over very large distances

There is a wide variety of linking systems in use. Some feature highly secure links, others feature access directly from your PC. Some systems offer DTMF control to radio users and many other features. Every system is different, and each has its following. In fact, one of the hardest things for new users of Internet linking to work out is what is fact, and what is uneducated opinion from people who have only used one or two systems, or have a strong preference for a particular secure system. (In my case EchoLink) Internet repeater links can be made with a variety of software and hardware. However, most fall into a number of broad categories, based on the technology used to make the link:

- Custom RF only links (e.g. [IRLP](#))
- Custom PC/RF links (e.g. [EchoLink](#), [eQSO](#))
- Commercial packaged systems (e.g. DStar & [Yaesu WIRES](#) series)

How it Works

The VoIP software - takes the audio from the receiver which is then fed into the sound card - where it is converted into digital data. The PC then converts this digital information into digital packets each assigned with IP addresses for the destination node. These packets now flow through the internet to the destination PC where the packets are decoded then sent to the sound card and out to the transmitter microphone of the link radio which then transmits the audio out over the local repeater. The transmitter is keyed as soon as these TCP/IP (Internet Protocol) packets start to arrive. As soon as the data stops the link radio automatically un-keys and process reverses.

There are some excellent web sites that describe the technicalities of VoIP, as well as the licensing requirements, in much more detail so a little more time on one of the search engines will turn up a wealth of information.

Check with your Licence Issuing body in your country as you may need permission to run an RF gateway. Licensed amateurs using the PC only will be exempt and will be able to use the system after their licence details have been validated by the administrators of the software you are using.

To establish a Echolink connection using RF Link

1. It is recommended that you first Listen Listen Listen and then identify your station on the Link/Repeater and that you are attempting an EchoLink operation.
2. Optionally, you can determine if the EchoLink gateway is operational by keying a "*" DTMF tone. The gateway node will respond with status information.
3. Key the four or five digit station code for the station or repeater that you wish to link to.
4. After a few seconds delay, the EchoLink node will respond with a "Connected" message if the link was successful. If the link was not successful, key a "#" to disconnect the gateway node.
5. Following a successful connection, announce your presence on the linked repeater by calling CQ, etc.
6. During a QSO using linked repeaters, let the repeater tail completely drop before transmitting to avoid any timeout problems.
7. At the end of the QSO, disconnect the link by keying a "#" DTMF tone. The EchoLink gateway will respond with confirmation that the link has been disconnected
8. There is about a 4 second delay when using the system so be patient.
9. When using RF a logbook must be kept

Accessing EchoLink From Your Computer

1. Download and install the EchoLink program from the EchoLink web site www.echolink.org. Check out the help files on installing the software
2. Verify that you have a microphone properly connected to your computer and the the microphone input volume level is properly adjusted.
3. Connect to the internet and run the EchoLink user program. When you connect for the first time you will have to have your callsign verified all this information is in the FAQ on the [EchoLink web site](http://www.echolink.org).
4. Select a station or repeater to link to from the displayed EchoLink station link.
5. Once connected and after Listening to make sure the system is not in use, use the spacebar to toggle between transmit and receive.
6. When using the PC for the contact then no log book needs to be kept.

It is suggested that you first visit EchoLink web site www.echolink.org for the software and information on how to use the system. It is not hard to use and set up. This will enable you to chat with ease to the many thousands of licensed Radio hams from all over the world already using EchoLink. I have found EchoLink to be the best for my needs but you might find the other system better for you.

Suggested Link / Repeater Operating Procedures

Link / Repeater Operation

1. Where links & repeaters are linked, your transmissions will be heard on the output of all the linked Repeaters, Gateway Links and PC Users so the golden rule is to listen listen listen.
2. Operation of a link is the same as a normal repeater, except that the coverage is much greater and simplex is used.
3. **Please remember that using the DTMF tones to move your link can be heard through the system and it can be annoying to others so keep them to a minimum also give your call sign and a brief explanation of what you are doing.**
4. **If you do move the link with the DTMF tones and connect to other Repeaters / Links don't forget to disconnect the link using the # key or 73.**
5. There is about a 4 second delay when working through the internet links so don't forget to leave a good gap between over's to enable others to break in.
6. Use simplex wherever possible freeing the link/repeater for necessary uses.
7. Monitor the link (listen) or determine if the link is in use, and if there are any peculiarities in its operation. After listening for a few seconds, identify, un key and listen to see if it was quiet for a reason, and to allow someone to let you know if there is a reason not to continue (low audio, low signal strength, etc). Then, if all OK, proceed.
8. Don't break into a contact unless you have something to add. Interrupting is no more polite on the air than it is in person. Interruption without identification constitutes malicious (and illegal) interference.
9. Use the minimum power to key up the repeater. To make contact, simply indicate that you are on frequency. For example "EI4JR monitoring". Do not kerchunk. (Keep PTT'ing)
10. Remember amateur radio transmissions are being monitored by many non-hams with scanners. Watch your language and your manners. Please don't bring disrepute on the Amateur Radio Service.
11. Repeaters are intended to facilitate mobile and portable operation. During rush hours, base stations should relinquish the repeater to commuting mobiles. Some repeater owners have strict rules requiring this.
12. Keep transmissions short and thoughtful. Do not monopolize the link. Pause between transmissions to allow other amateurs to identify themselves if they wish to use the link. Pausing also allows the timer on some of the connected repeaters to reset, avoiding a "time-out"
13. Identify legally. In Ireland & the UK that means at the beginning and end of a contact or every 15 minutes of operation.
14. Links are installed and maintained at considerable expense and inconvenience. Regular users of a link should financially support the individual or club owner in their efforts to keep the link working properly.
15. When called by one of the local amateurs directly on the link frequency and there is no QSO through the link move to one of the simplex frequencies to continue your QSO so as not to stop others using the Link.

www.echoireland.com

DTMF Functions

Please remember that using the DTMF tones can be heard through the connected links & repeaters and can be annoying to others so keep them to a minimum also give your call sign and a brief explanation of what you are doing.

If you do move the link with DTMF tones and connect to other Repeaters / Links don't forget to disconnect the repeater when you have finished using "#"

There can be about a 4 second delay when working through the internet links so don't forget to leave a good gap between overs to enable others to break in and connecting repeaters to reset.

The table below lists each of the common EchoLink DTMF commands.

Command	Description	Default
Connect	Connects to a station on the Internet, based on its node number.	num
Connect by Call	Connects to a station on the Internet, based on its call sign.	C+call+#
Random Node	Selects an available node (of any type) at random, and tries to connect to it.	00
Random Link	Selects an available link or repeater (-L or -R) at random, and tries to connect to it.	01
Random Conf	Selects a conference server at random, and tries to connect to it.	02
Random User	Selects an available single-user station at random, and tries to connect to it.	03
RandomFavNode	Selects an available node (of any type) at random from the Favorites List, and tries to connect to it.	001
RandomFavLink	Selects an available link or repeater (-L or -R) at random from the Favorites List, and tries to connect to it.	011
RandomFavConf	Selects a conference server at random from the Favorites List, and tries to connect to it.	021
RandomFavUser	Selects an available single-user station at random, and tries to connect to it.	031
Disconnect	Disconnects the station that is currently connected. If more than one station is connected, disconnects only the most-recently-connected station.	#
Disconnect All	Disconnects all stations.	73
Reconnect	Re-connects to the station that most recently disconnected.	09
Status	Announces the call sign of each station currently connected.	08

There are many stations connected to the EchoLink system at any one time and each station has a unique node number which can be entered by DTMF to connect to them. There are quiet a few thousand stations from all over the world registered to the system and to many to list here so either visit the EchoLink website at www.echolink.org or simply ask the station that you are in QSO with to let you know what their node number is or the node number of the link they are using.

Don't forget its your link so be proud of it and help others who need help using it and if there is any thing that you can think of to improve your Link drop me an email peter@ei4jr.com

Function	Description	Short Cut	In Use
TIME	Time Announcement	123	✓
HELP	Simple HELP on access to the link	88*	
INTRO	Location link information	00#	
STATUS	Node Status	08	✓
Weather	Listen to Current Weather (From Malin Head)	99*	✓
Weather	Listen to Forecast Weather (From Malin Head)	44*	✓
Auto Con	Auto Connect (Ireland Conference Server) on/off	*0*	Toggle
Node	Node Busy (Ireland Conference Server) on/off	*1*	Toggle
TEXT Message	Say text messages when sent to EchoLink via internet on/off	*2*	Toggle

www.echoireland.com

North Donegal Internet Repeater

EI2IPG - EI0IPG Repeater User Guide

145.7125 MHz / 145.1125 MHz - 29.680 / 29.680 MHz

EI2IPG & EI0IPG have established on the EchoLink system and is well visited by many hundreds of radio amateurs from every part of the world via the internet and has become a meeting point on the EchoLink system via the *IRELAND* conference server for many amateurs. For more information on EchoLink visit their web site www.echolink.org

We have found there are a lot of new and old amateurs who are not sure how a Link / Repeater is used and with the added internet connection is a little confusing so we have put together some guidelines that are used on the EI2IPG Repeater that might help.

You will always find operators who will to give you advice in the true amateur fashion on the do's and don'ts of your local link / repeater so don't be afraid to ask as they were the same as you once. Remember that a lot of links / repeaters are 12.5k and that the audio needs to be set to narrow deviation.

Getting access to the Repeater

To gain access to the EI2IPG or EI0IPG repeater when it is not in operation you provide a CTCSS tone set at 67Hz while transmitting and keep the transmitter on for 6 seconds in which time you will give your call sign. This will open the repeater and when accessed you will hear a your signal report in Morse "S"trong(...), "I"ntermediate (..), "W"eak (--) this will be followed by 8 pips. (E ".") If there is a transmission from the internet you will hear an "N"et (-.)

Once the repeater is open no other tone is required and it will stay open while it is in use.

The repeater will give a signal report (S,I or W) the end of a transmission that lasts longer than 5 seconds and if you wait for the 1st pip "E" (.) each time its your over it will allow others to break in and give those who are on the internet a chance to be heard.

If there is transmissions coming from the internet an "N" (-.) in Morse will be transmitted once you hear the "N" you can transmit back to that station.

The trick with internet repeaters is to leave a good gap of about 4 seconds between over's this will enable all the links and repeaters in the chain to re set.

If you have no tone burst or CTCSS tone you could try whistling it up (around 1750 Hz) or you can wait for one of the repeater announcement as this will open the repeater for about 10 seconds before closing down again.

The EI2IPG repeater has a 5 minute time out where time out tones and pips will be heard at the same time as the rag chewer is talking then close down.

When a user on the internet users times the repeater out (5 Minuet time out) a series of "T"s are sent and the repeater closes down. The RF user can activate the repeater as normal and talk to other local RF users until the internet rag chewer finishes. When the internet is in time out mode the pips ("I" ".") will be replaced with a "T" ("-") till the internet rag chewer finishes then the system will revert back to normal.

The Morse ident is set to 12 words per minute

To check what stations if any connected to the link using your DTMF mic transmit giving your call sign first and dialling 08* and release the PTT. this should result in a list of stations connected verbally sent to you or if none connected a "Not Connected" will be returned.

The Repeater call sign (EI2IPG) will be transmitted every 15 minuets along with information stating if the link is ON /OFF or one of the random messages. It will not tell you what stations are connected but this can easy be found by using a DTMF pad and sending 08* to the link. Remember always announce what you are trying to do with the DTMF.

CW letters sent by the EI2IPG repeater		
CW Letter	Morse	Description
S	...	Strong Signal into the repeater (S = Strong)
I	..	Intermediate Signal into the repeater (I = Intermediate)
W	..-	Weak Signal into the repeater (W = Weak)
E	.	Tail Pips sent before the repeater closes
N	-.	Sent when information comes from the Internet
T	-	Sent when Internet users times out
3 Tones		Sent when user times out

A Simple Radio to PC Interface that can be used for your RF gateway

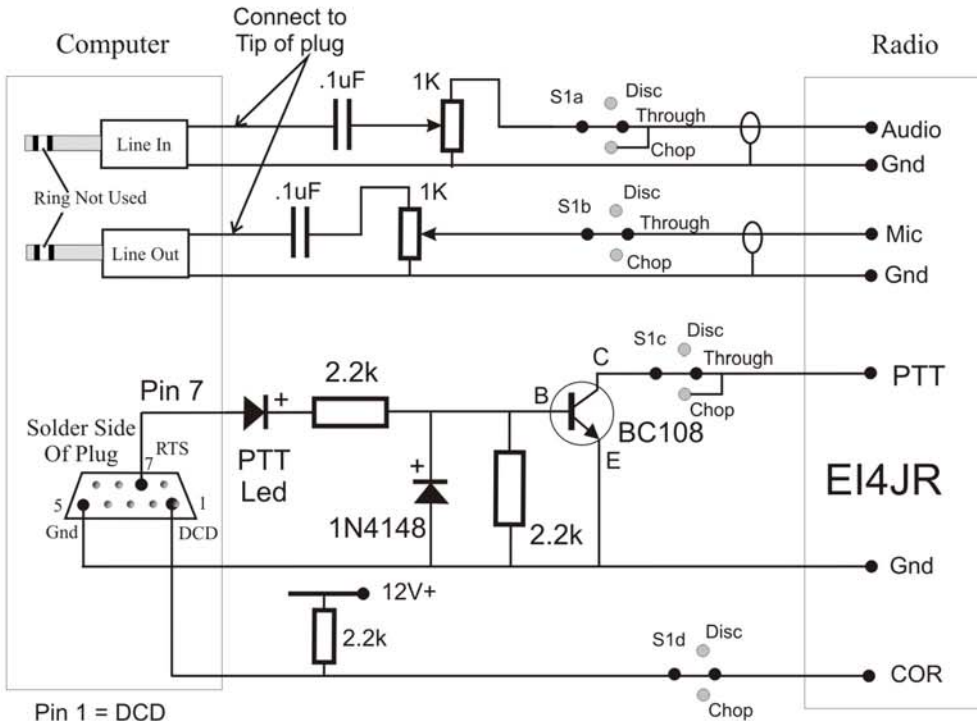
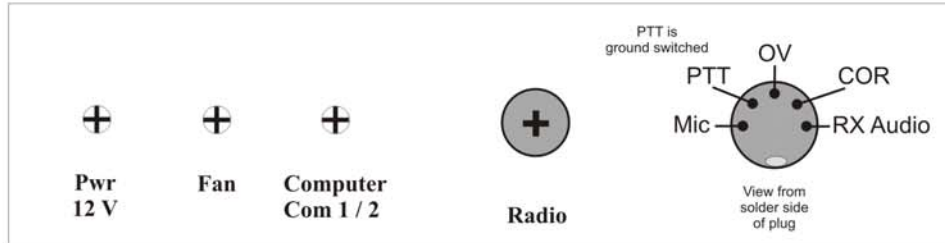
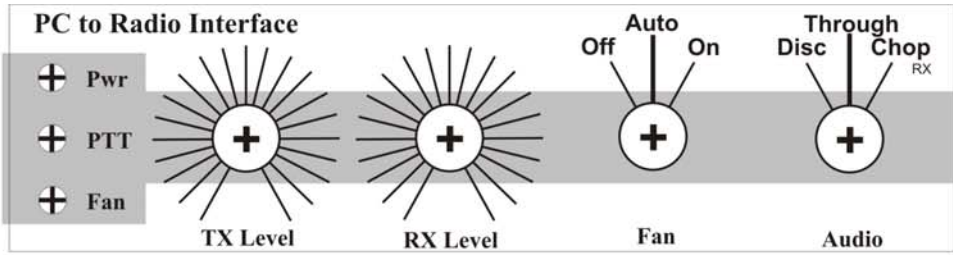

Pin 1 = DCD
 Pin 4 = DTR
 Pin 5 = Gnd
 Pin 7 = RTS

Fan Control used by EchoProducer Program

